

**HAFCO WOODMASTER**

# WOOD LATHE OPERATION MANUAL



**Models  
WL-18, WL-20**

*Edition No : WL-001*

*Date of Issue : 01/2018*

[www.machineryhouse.com.au](http://www.machineryhouse.com.au)



# OPERATION MANUAL

## MACHINE DETAILS

<b>MACHINE</b>	<input type="text" value="WOOD LATHE"/>
<b>MODEL NO.</b>	<input type="text"/>
<b>SERIAL NO.</b>	<input type="text"/>
<b>DATE OF MANF.</b>	<input type="text"/>

Distributed by



[www.machineryhouse.com.au](http://www.machineryhouse.com.au)

[www.machineryhouse.co.nz](http://www.machineryhouse.co.nz)

**NOTE:**

This manual is only for your reference. Owing to the continuous improvement of the HAFCO machines, changes may be made at any time without obligation or notice. Please ensure the local voltage is the same as listed on the specification plate before operating an electric machine.



**NOTE:**

In order to see the type and model of the machine, please see the specification plate. Usually found on the back of the machine. See example (Fig.1)

**PRODUCT SPECIFICATION**

**MODEL:**

**CAPACITY:**

**SER. NO.:**

**MFG DATE:**

**WEIGHT:**

**VOLTS:**

**MOTOR Kw:**

[www.machineryhouse.com.au](http://www.machineryhouse.com.au)  
Made in China

Fig.1

**OPERATION MANUAL**

---

**CONTENTS:**

SPECIFICATIONS.....	4
FEATURES.....	5
IDENTIFICATION.....	6
SAFE WORK PROCEDURE.....	7
Before Operating Safety Checks.....	7
Operating Safety Checks.....	7
After Operations And Clean Up.....	7
Potential Hazards And Don'ts.....	8
SAFETY PRECAUTIONS.....	8
ASSEMBLY.....	9
Unpacking.....	9
Assembling The Legs.....	10
Assembling The Lathe On The Legs.....	10
Head Lock Handle.....	10
Installing Spurs.....	11
Installing Face Plate.....	11
Installing Extension Bed.....	11
Setup Of Gearbox.....	12
ADJUSTMENTS.....	12
Headstock.....	12
CONNECTING TO THE POWER SUPPLY.....	13
OPERATING INSTRUCTIONS.....	13
Basic Controls.....	14
Changing Speeds.....	14
Tailstock Controls.....	15
Tool Rest.....	15
Outboard Turning.....	15
MAINTENANCE.....	16
Schedule.....	16
Cleaning.....	16
Lubrication.....	17
Troubleshooting.....	18
SPARE PARTS.....	19
RISK ASSESSMENT.....	25

## OPERATION MANUAL

### 1.1 SPECIFICATIONS

Model	WL-18	WL-20
<b>Main Specifications:</b>		
Swing Over Bed (mm)	310	370
Swing Over Tool Rest Base (mm)	230	290
Distance Between Centres (mm)	900	1100
Max. Distance Tool Rest to Spindle Center (mm)	340	340
No of Spindle Speeds	Variable	Variable
Spindle Speed Range (2 Steps)(r.p.m.)	500-2000	500-2000
<b>Electrical:</b>		
Power Requirement	240V, 50 Hz,1P	240V, 50 Hz,1P
Full-Load Current Rating (Amps)	6	6
Minimum Circuit Size (Amps)	10	10
Switch Type	Magnetic Switch	Magnetic Switch
<b>Motors:</b>		
Power (kW/HP)	0.75/1	0.75/1
Speed	1400	1400
Power Transfer	Belt Drive	Belt Drive
<b>Spindle Information:</b>		
Spindle Taper	MT2	MT2
Spindle Thread Size	1" x 10tpi.	1" x 10tpi
Spindle Thread Direction	R/H	R/H
Spindle Bore (mm)	10.6	10.6
<b>Tool Rest Information:</b>		
Tool Rest Width. (mm)	300	300
Tool Rest Post Diameter. (mm)	25	25
Tool Rest Post Length (mm)	55	55
<b>Tailstock Information</b>		
Tailstock Taper	MT2	MT2
<b>Product Dimensions:</b>		
Weight (kgs)	85	97
Size: Width x Depth x Height (mm)	1610 x 650 x 1120	1650 x 680 x 1165
Footprint (Length x Width) (mm)	1700 x 700	1700 x 730
Packing Size (W x D x H) (mm)	1370 x 320 x 360	1600 x 330 x 440

**HAFCO WOODMASTER****OPERATION MANUAL****FEATURES**

By following the instructions and procedures laid out in this owner's manual, you will receive years of excellent service and satisfaction. This wood lathe is a professional tool and like all power tools, proper care and safety procedures should be adhered to.

**Solid Construction**

Well proven design. The critical components of the WL-18,20 Wood Lathes are made from cast-iron for strength, rigidity and vibration reduction.

**Speed Range**

The WL-18,20 Variable speed Wood Lathes have a variable speed range of 500-2000 rpm. . Variable Speed is achieved by a 10 stage quick dial-in lever mounted on the headstock. This allows for the correct speed for the job, material and conditions..

**Lathe Stand**

The machines are supplied with a stand as standard accessory.

**Swivel Head**

The machines are supplied with swivel heads with positive locks to allow for bowl turning. (As displayed below)



**1.2 IDENTIFICATION**



## OPERATION MANUAL

### 2. SAFE WORK PROCEDURE

**DO NOT use this machine unless you have read the instructions and understand the safe use and operation of the machine**



Dust masks must be worn at all times in work areas



Sturdy footwear should be worn at all times in work areas.



Safety glasses must be worn at all times in work areas. Hearing protection may be required.



Disconnect the machine from the power before any adjustments or servicing is commenced



Long and loose hair must be contained. Close fitting/protective clothing must be worn



Read and understand the manual before operating. Keep the manual in a safe place for future reference

#### BEFORE OPERATING SAFETY CHECKS

- Locate and ensure you are familiar with all machine operations and controls.
- Ensure all guards are fitted, secure and functional. Do not operate if guards are missing or faulty.
- Check workspaces and walkways to ensure no slip/trip hazards are present.
- Ensure the workpiece has been suitably prepared for the lathe operation.
- Workpiece must be securely fastened to face plate, chuck or between centres.
- Adjust speed to suit the diameter of the work and turning operation.
- Rotate the workpiece by hand to check clearance between tool rest and bed.
- Ensure the cutting tools are sharp and in good condition.
- Start the dust extraction unit before using the machine.

#### OPERATING SAFETY CHECKS

- Only one person may operate this machine at any one time.
- Before making adjustments, switch off and bring the machine to a complete standstill.
- Keep the tool rest adjusted close to the work and at the correct height.
- Adjust speed to suit the diameter of the work and turning operation.
- Stop the lathe and remove all tool rests before sanding.

#### AFTER OPERATIONS AND CLEAN UP

- Switch off the machine when work completed.
- Return all chisels and other tools to their rightful place
- Clean and cover the tool rests with a light oil
- Leave the machine in a safe, clean and tidy state.

**OPERATION MANUAL****2. SAFE WORK PROCEDURE Cont.****POTENTIAL HAZARDS AND INJURIES**

- Eye injuries from flying debris or defective timber.
- Hair/clothing getting caught in moving machine parts.
- Airborne dust.

**DON'T**

- Do not use faulty equipment. Immediately stop using the suspect equipment.
- Never leave the machine running unattended.

**SAFETY PRECAUTIONS**

- Keep the tool on the tool rest. Tools should remain on the tool rest whenever the tool is engaged in the work piece.
- Remove the tool rest when sanding or polishing so fingers do not get pinched.
- Direction of feed. Feed work into blade or cutter only against the direction of rotation of work piece.
- Use the correct lathe tools. Do not use spindle turning chisels for faceplate mounted work or vice versa. Spindle turning tools used for faceplate turning may grab the work piece and pull the chisel from your control.
- When roughing be careful not to jam the lathe tool or chisel into work piece
- Do not use excessive force when attaching the work piece onto the headstock drive (spur) centre. Use a soft mallet.
- Do not use the tailstock to drive the work piece onto the drive spur centre when turning between centres. Secure with light pressure from the tailstock.
- When turning between centres, make sure the tailstock is locked before operating
- Never loosen the tailstock spindle or tailstock while work piece is turning.
- When faceplate turning, make sure work piece is securely fastened to the faceplate and that the appropriate size faceplate is used to support the work piece. Any screw fasteners must not interfere with the turning tool at the finished dimension of the work piece. Rough cut the work piece as close as possible to the finished shape before installing it on the faceplate.
- Do not operate the lathe if it is damaged or faulty. If any part(s) of the lathe is missing, damaged or broken, in any way, stop the lathe and disconnect it from the power supply. Replace missing, damaged, or failed parts before resuming the operation.
- The spindle threads are sharp and should not be used to lift the lathe, or to stop the rotation the spindle.



**Always use the correct tool for the job.  
DO NOT use the machine for operations  
it was not designed for**

**ASSEMBLY**

**Unpacking**

Your machine was carefully packaged for safe transportation. Remove the packaging materials from around your machine and inspect it. If you discover any damage, contact your dealer

**Caution:** the wood lathe is very heavy and will require the help of 2 or more people to lift. The assembly process will also require help to safely assemble the lathe to the leg set.

1. Carefully remove the leg set and wood lathe from the carton.
2. Separate the parts for the leg set from the parts of the lathe.
3. Lay out all parts and check them against the parts listed below. Examine all parts carefully.

**Warning:** If any part is missing or damaged, DO NOT plug the wood lathe in until you have replaced the missing or damaged part.

For your safety, complete the assembly of the lathe before plugging it into the power supply.

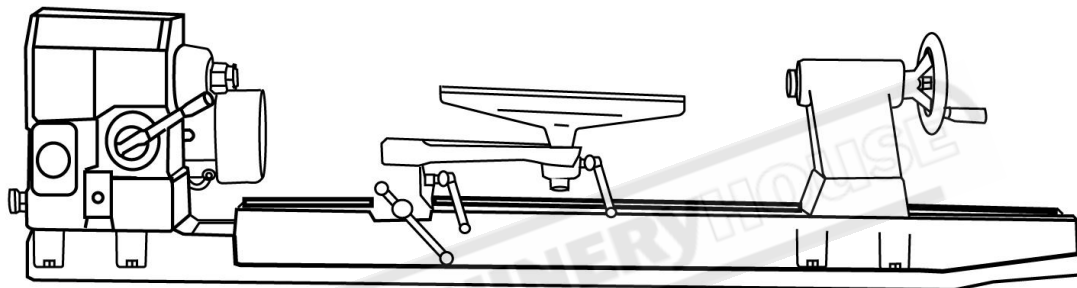

Lathe Bed Assembly

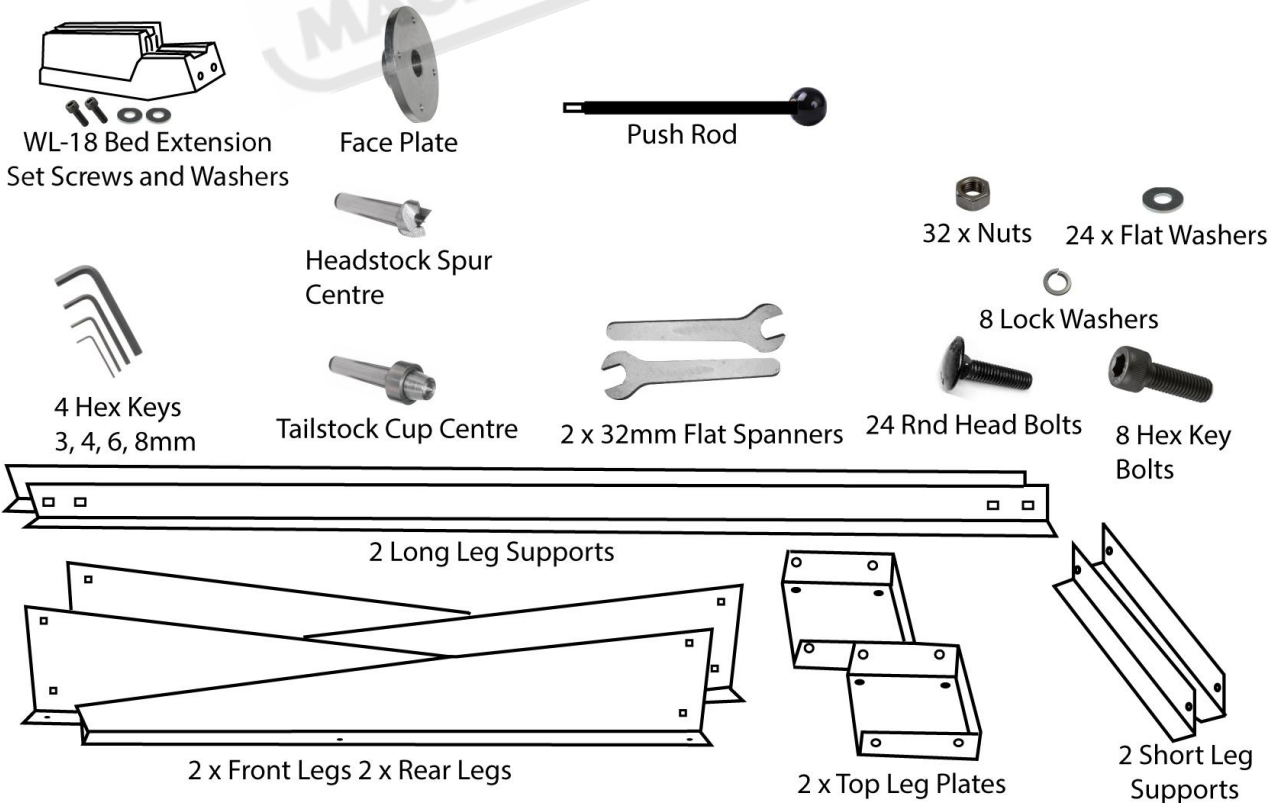

### Assembling The Legs (Fig.3.1)

1. Attach one front and one back leg [1] to the outside edge of the top plate [2], using carriage bolts (3), washers [4], and nuts [5].
2. Position the top plate so that it fits inside the legs.
3. Repeat step 1 for the opposite side.
4. Attach long supports [6] to legs using carriage bolts, washers and nuts.
5. Attach short supports [7] to legs using carriage bolts, washers and nuts.
6. Place the stand on a level surface and tighten all nuts securely using a wrench.

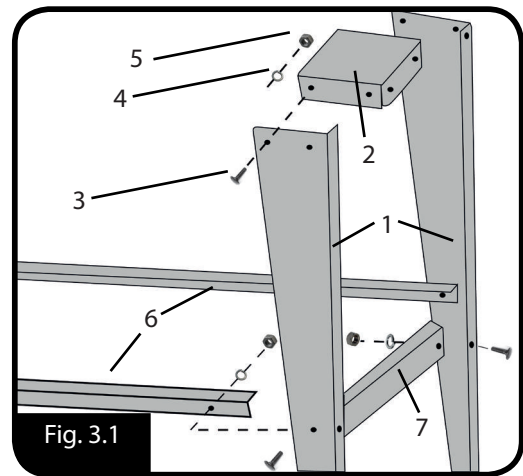

### Assembling The Lathe On The Legs (Fig.3.2)

1. Place the lathe bed assembly on the leg set.
2. Position the headstock assembly over the top plate and align the holes in the bed with the holes in the top plate [1]. Set the headstock down carefully.
3. Place the bolts [2] through the lathe and into the holes on the top plate [1]
3. Align tailstock assembly end of the lathe over the top plate mounting holes and set it down carefully.
4. Insert the hex bolts [2] into the mounting holes in the bed and into the top plate.
5. Thread washer [3] and nut [4] onto bolt [2] and securely tighten.

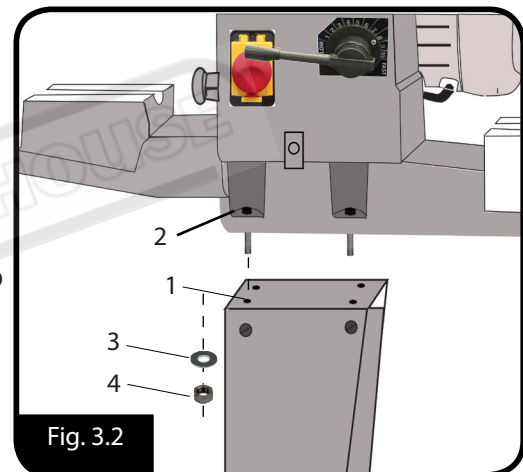

### Head Lock Handle (Fig. 3.3)

1. Locate and assemble the head locking handle [1], spring [2] and bolt [3] as shown.
2. Thread the assembled handle onto the head locking clamp [4] and tighten.

#### NOTE:

The spring loaded handles on the lathe are designed to minimize interference with other lathe parts or the workpiece. To operate, push the handle lever in and turn clockwise to tighten. Releasing the handle lever will disengage the threaded shaft, allowing you to reposition the lever handle so it is out of the way

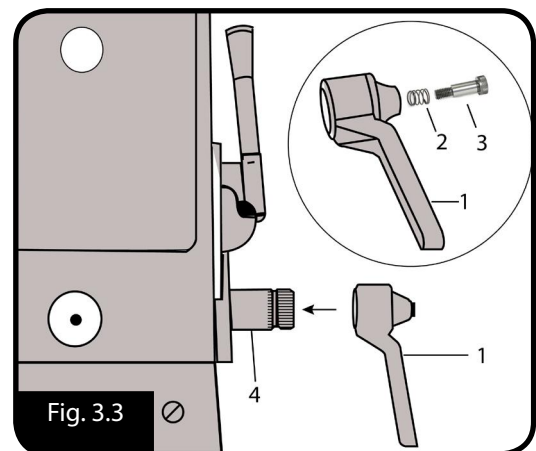

### Installing Spurs (Fig.3.4)

1. Remove the faceplate [1] from the headstock spindle using the two wrenches provided [2] to separate the faceplate from the spindle nut.
2. Insert the headstock spur [3] in the spindle hole.
3. Insert the tailstock centre [4] in the tailstock hole.
4. To remove either the headstock spur or the tailstock centre, insert the push-out rod [5] into the hole [6] at the opposite end of the headstock or tailstock and lightly tap..  
Remove and store the rod in a safe location after use.

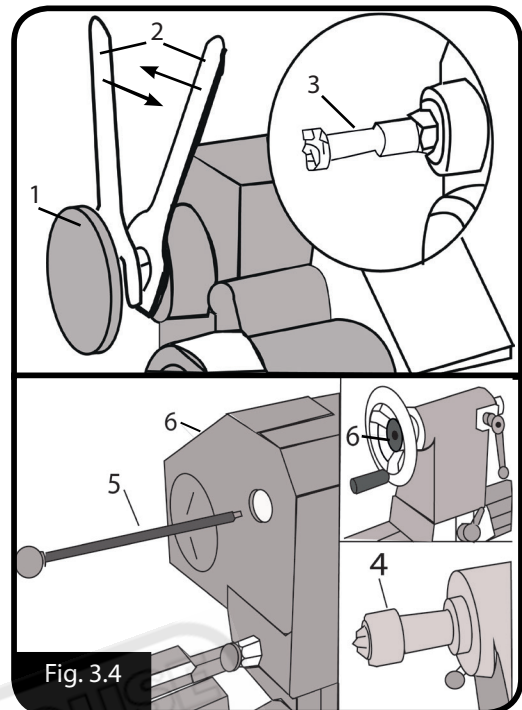

### Installing Face Plate (Fig.3.5)

1. Remove the headstock spur from the spindle.
2. Thread the 100mm diameter faceplate to the spindle.
3. Mount the workpiece to the faceplate with flat head brass wood screws as shown.  
Make sure the length of the screws does not interfere with the cutting tools.

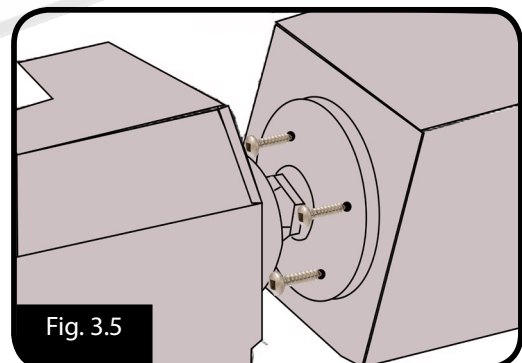

### Installing Extension Bed WL-18 Only(Fig.3.6)

1. The extension bed is attached to the left of the headstock for outboard faceplate turning when the use of the tool rest is required.
2. If outboard faceplate turning does not require the use of the tool rest, do not attach the extension bed until needed.
3. To attach the extension bed [1] to the bed, align the bolt holes [2] with the treaded bed holes [3]. Put the lock washer [4] on the hex bolt [5]. First finger tighten the hex bolt, then secure the hex bolt with the hex key provided.

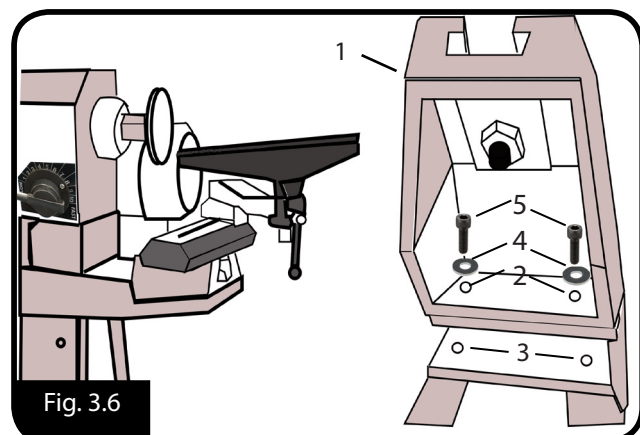

### Setup Of The Headstock (Fig.3.7)

For safety during storage and transportation the headstock has been fixed to the guide way using a setscrew bolt [a]

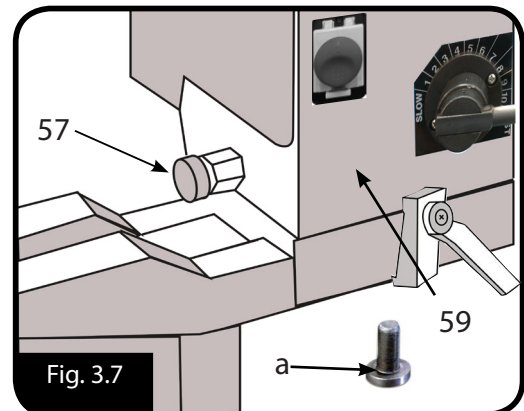
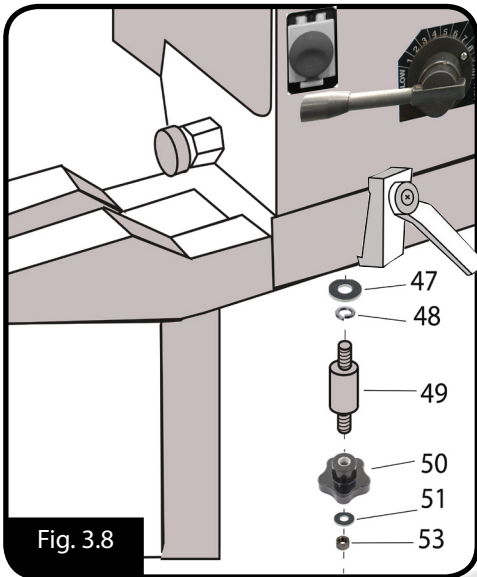

1. After the wood lathe has been assembled and before operation, remove the set screw bolt [a] and screw in the locking shaft [49] using washers [ 47 & 48]
2. Put the Hand wheel [50] onto the locking shaft [ 49] and turn the hand wheel to secure.
3. The hand wheel can be fixed to the locking shaft using set screw {53} with washer [51]. (Fig.3.8)

## ADJUSTMENTS

### Headstock (Fig.3.9)

1. The headstock has four preset positions. Zero setting for all spindle turning applications. 60° / 90° / 120° for use when making face plate turnings, and 180° for face plate turning when using the extension bed and tool rest.
2. To set the headstock at the desired position, you must first turn the head lock handle [1] until you have completed at least one rotation. (Fig. 3.9)
3. Pull out the headstock location pin [2]. Rotate the entire headstock clockwise to the desired setting. The headstock will be fixed in position when the location pin clicks into one of the five preset settings. Tighten the lock handle [1].

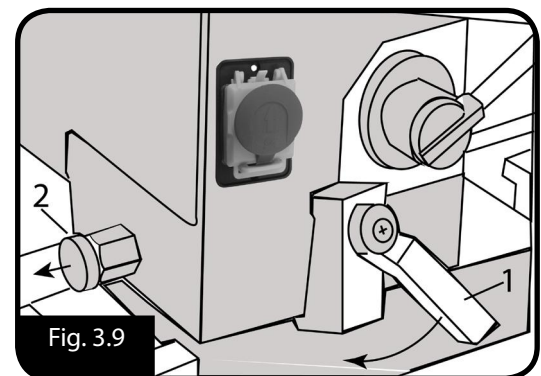

**WARNING:** DO NOT TURN THE HEADSTOCK ASSEMBLY MORE THAN 180° CLOCKWISE FROM THE ZERO SPINDLE SETTING POSITION OR DAMAGE TO THE WIRING MAY OCCUR.

**CONNECTING TO THE POWER SUPPLY:**

The electric motor, switch, cord and controllers are supplied with the WL-18,20 Wood Lathes. The plug must be plugged into a matching outlet that is properly installed and grounded in accordance with local electrical codes. The power cord must have a earth pin.



Improper connection of the motor can result in a risk of electrical shock.

If it is necessary to use an extension lead, the lead should be grounded and be able to carry the correct amperage. Use a short lead length, to avoid power loss and over-heating.

**IMPORTANT:** An extension lead should only be used as an interim solution until the machine can be plugged directly into the socket. For best protection of the lathe, if possible use a surge-protected plug outlet rated to at least 10 amps.

**OPERATING INSTRUCTIONS**

This overview is to provide the novice machine operator with a basic understanding of how the machine is used during operation, so the machine controls/components discussed later in this manual are easier to understand.

The generic nature of this overview, is not intended to be an instructional guide. To learn more about specific operations, read this entire manual and seek additional training from people who have experience with how the machine operates. Seek additional information by reading "how-to" books, trade magazines, or websites.

The operator should follow the advice listed below.

1. Examines the workpiece to make sure the timber is not bowed, or has cracks and is suitable for turning.
2. Trim up the workpiece with a bandsaw or table saw to make it roughly concentric.
3. Install the workpiece between centers, or attach it to a faceplate or chuck.
4. Adjust the tool rest to 13mm above the workpiece centerline, and set the minimum clearance gap between the workpiece and the lip of the tool rest to 6mm.
5. Rotate the workpiece by hand to verify that the spindle and workpiece rotate freely to ensure there is clearance throughout the full range of motion.
6. Position any dust collection hoods near the workpiece to collect wood chips and secure it in place.
7. Verify that the appropriate speed range has been chosen for the, type of wood, and size of workpiece.
8. Tie back loose hair and clothing, and use a face shield and respirator. Take all other required safety precautions.
9. Start the dust collector (if available) then start the lathe at the slow speed, then adjust the lathe to the speed required, and carefully begin the turning operation, keeping the chisel against the tool rest the entire time it is cutting.

**OPERATING INSTRUCTIONS Cont.**
**Basic Controls**

**Switch:** To turn the lathe 'ON', release the catch that holds the yellow top locked down, then the ON/OFF buttons are exposed. Press the "O" button to switch the machine on and press "I" to turn the lathe 'OFF'.

To lock the switch in the 'OFF' position, press the large red knob in the middle of the yellow door. Once the button has been pressed the yellow door will be locked in place and access to the ON/OFF buttons removed.

**NOTE:** Never leave the lathe unattended until it has come to a complete stop.

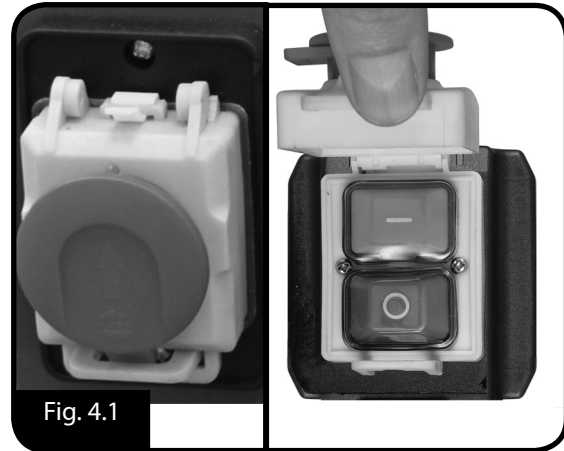

Fig. 4.1

**Changing Speeds: (Fig.4.2)** This lever controls the spindle speed

**Speed Control Lever:**

1. The lathe motor must be running before you can use the speed control lever.
2. The speed control lever can be set to one of 10 speeds. To set the speed, pull back on the lever handle (1) and rotate the handle to the next fixed position. Use the index plate (2) to choose lathe speed. (Fig. 4.3)
3. Turn the lever clockwise to increase the speed and counter-clockwise to decrease the speed.
4. The speed control lever should be moved to the lowest speed setting before turning the lathe off.

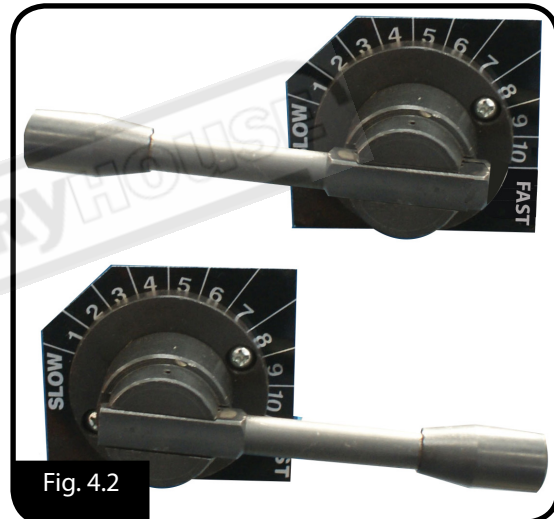

Fig. 4.2

Fig. 4.3

WORKPIECE DIAMETER	ROUGHING R.P.M.	GENERAL CUTTING R.P.M.	FINISHING R.P.M.
< 50mm	1400	2000	2000
50 - 100mm	760	1600	1790
100 - 150mm	500	1080	1210
150 - 200mm	300	620	1210
200 - 250mm	250	500	900
250 - 300mm	200	500	700
> 300mm	150	500	620

**NOTE:** Speeds listed in the table are suggested only and may not be suitable for all situations

### Tailstock Controls:

The tailstock is used to support long work by the use of a live centre. The tailstock quill accepts the centres and accessories with a No. 2 Morse taper.

1. Move the tailstock (1) by loosening the lock lever (2) and pushing the tailstock to the desired position on the bed. Lock by tightening the lock lever [2]
2. The spindle can extend up to 60mm from the tailstock housing. You can move the tailstock spindle [3] by loosening the spindle lock lever [4] and then turning the hand wheel [5]. Lock levers (4) & (2) before operating the lathe.
3. The tailstock spindle is hollow and can be accessed from the handwheel end. Use the push-out rod to remove the live centre or drill chuck through the centre of a workpiece.

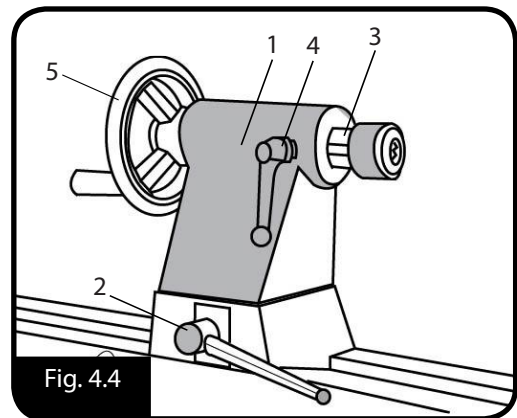

Fig. 4.4

### Tool Rest

1. To move the Tool Slide along the bed, loosen the camshaft handle, move the tool slide to the desired position and tighten the cam shaft handle.
2. To adjust the Tool Rest, loosen the Tool Rest Lock Handle, position the Tool Rest, and tighten the Tool Rest Lock Handle.
3. Adjust the Tool Rest close to the work piece. Exact positioning may be varied to suit the turner. Before turning, rotate the stock, by hand, to make sure it clears the Tool Rest. At intervals, stop the lathe and readjust the Tool Rest.

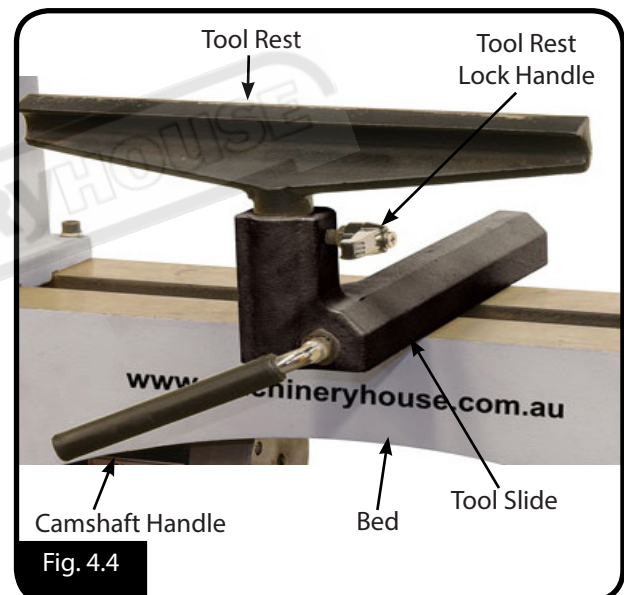

Fig. 4.4



Fig. 4.5

### Outboard Turning

Outboard turning is accomplished with the headstock positioned so the faceplate is not directly over the bed, allowing a larger turning capacity than the swing of the lathe.

**WL-18** requires the extension bed to be used to support the toolrest.

**WL-20** Allows the headstock to slide along the bed and be set in any position. Loosened the headstock and slide the head towards the tailstock until there is enough room for the toolrest to be mounted. (Fig.4.5)

## MAINTENANCE

After each use, clean the work area and lathe. Vacuum scraps and dust from the inside of the headstock, between the lathe Bed, and under the tool slide and tailstock. Do not neglect this especially if the work piece was 'green' with excess moisture. Failure to clean-up after green turning can cause rust marks and pitting of the surfaces of the lathe.

If the tool slide becomes hard to move and adjust, cleaning and lubricating is required. If the tailstock quill becomes hard to use or the hand wheel is hard to turn, cleaning and lubricating is required.

Keep the motor free of saw dust and wood chips, especially around the fan housing. Periodically check for any abnormal noise or excessive heat.

## Schedule

For optimum performance from your machine, follow this maintenance schedule and refer to any specific instructions given in this section.

### Daily Check:

- For loose mounting bolts.
- Worn or damaged wires.
- Worn switch
- For any other unsafe condition

### Monthly Check:

- Belt tension, damage, or wear.
- Clean/vacuum dust buildup off of motor.

## Cleaning

Cleaning a wood lathe is relatively easy. Vacuum excess wood chips and sawdust, and wipe off the remaining dust with a dry cloth. If any resin has built up, use a resin dissolving cleaner to remove it. Treat all unpainted cast iron and steel with a non-staining lubricant after cleaning. Protect the unpainted cast iron surfaces on the lathe by wiping them clean after every use, this ensures moisture from wood dust does not remain on bare metal surfaces.

**MAINTENANCE Cont.****Lubrication**

**⚠ WARNING** FOR YOUR OWN SAFETY, TURN THE LATHE OFF AND DISCONNECT THE POWER PLUG FROM THE POWER SUPPLY BEFORE PERFORMING ANY MAINTENANCE OR LUBRICATION WORK ON THE LATHE.

- Vacuum and/or blow out any dust accumulation inside the motor housing on a regular basis.
- Apply a coat of paste wax to the lathe bed to help keep it clean and to facilitate the easy movement of the articulated tool rest and tailstock.
- Proper Oiling and maintenance must take place to ensure the quality and life of the machine. To Maintain this, the use of a pin point oiler would be helpful. Take the headstock cover off, and oil the point. This should be done periodically.

Periodic lubrication (white grease) of the spring levers and other threaded parts will make them easier to operate and prevent any possible corrosion.

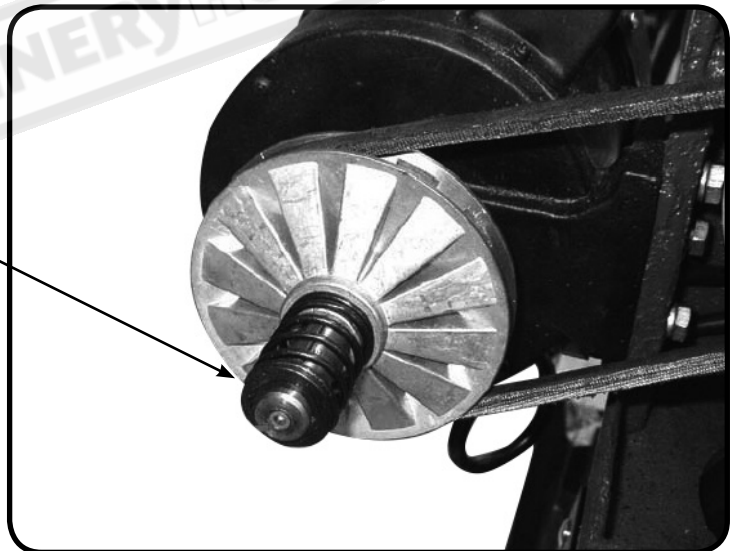

## OPERATION MANUAL

### Troubleshooting

Symptom	Possible Cause	Possible Solution
Machine does not start or a breaker trips.	<ol style="list-style-type: none"> <li>1. Plug or socket is at fault or wired incorrectly.</li> <li>2. Power supply is at fault/switched OFF.</li> <li>3. Motor ON button or ON/OFF switch is at fault.</li> <li>4. Wiring is at fault.</li> <li>5. Motor is at fault.</li> </ol>	<ol style="list-style-type: none"> <li>1. Test for good contacts; correct the wiring.</li> <li>2. Ensure correct voltage and main power supply is switched ON.</li> <li>3. Replace faulty ON/OFF switch.</li> <li>4. Check for broken wires test and repair/replace as necessary.</li> <li>5. Test the motor and repair or replace.</li> </ol>
Machine stalls or is under powered.	<ol style="list-style-type: none"> <li>1. Plug/socket is at fault.</li> <li>2. Motor bearings are at fault.</li> <li>3. Motor has overheated.</li> <li>4. Motor is at fault.</li> </ol>	<ol style="list-style-type: none"> <li>1. Test for good contacts; correct the wiring.</li> <li>2. Test by rotating shaft; rotational grinding/loose shaft requires bearing replacement.</li> <li>3. Clean off motor, let cool, and reduce workload.</li> <li>4. Test/repair/replace.</li> </ol>
Machine has a vibration or noisy operation.	<ol style="list-style-type: none"> <li>1. Motor or component is loose.</li> <li>2. Motor fan is rubbing on fan cover.</li> <li>3. Workpiece or chuck is at fault.</li> <li>4. Motor bearings are at fault.</li> </ol>	<ol style="list-style-type: none"> <li>1. Inspect/replace damaged bolts/nuts, and re-tighten</li> <li>2. Replace dented fan cover; replace loose/damaged fan.</li> <li>3. Center workpiece in chuck or face plate; reduce rpm; replace defective chuck.</li> <li>4. Test by rotating shaft; rotational grinding/loose shaft requires bearing replacement.</li> </ol>
Vibration noise while machine is running or when speed is changed	<ol style="list-style-type: none"> <li>1. Belt cover loose.</li> <li>2. Belt cover bent or dented and is making contact with the motor pulley or belt.</li> </ol>	<ol style="list-style-type: none"> <li>1. Tighten the belt cover</li> <li>2. Remove belt cover and inspect the inside for dents or bends, or indications of rubbing. Tap out the dent with a rubber mallet, bend back into proper shape, or shim belt cover away from the motor pulley.</li> </ol>
Motor is running but spindle is not turning.	<ol style="list-style-type: none"> <li>1. Belt is loose, broken, or has come off the pulley.</li> <li>2. Belt broken</li> </ol>	<ol style="list-style-type: none"> <li>1. Inspect belt and tighten, reinstall, or replace if damaged.</li> <li>2. Replace the belt</li> </ol>
Chisels grab or dig into the workpiece.	<ol style="list-style-type: none"> <li>1. Tool rest set too low.</li> <li>2. Tool rest set too far from workpiece.</li> <li>3. Wrong chisel/tool being used.</li> <li>4. Chisel/tool dull.</li> </ol>	<ol style="list-style-type: none"> <li>1. Set tool rest higher.</li> <li>2. Move the tool rest closer to the workpiece.</li> <li>3. Use the correct tool; educate yourself by reading trade books or seek help from an experienced lathe operator.</li> </ol>
Bad surface finish.	<ol style="list-style-type: none"> <li>1. Wrong spindle speed.</li> <li>2. Dull chisel or wrong chisel being used for the operation.</li> </ol>	<ol style="list-style-type: none"> <li>1. Use trial-and-error to find a better spindle speed.</li> <li>2. Sharpen chisel or try a different chisel.</li> </ol>
Tailstock moves	<ol style="list-style-type: none"> <li>1. Tailstock mounting bolt loose.</li> <li>2. Too much clamping pressure applied by tailstock.</li> <li>3. Bed surface is oily or greasy.</li> </ol>	<ol style="list-style-type: none"> <li>1. Tighten.</li> <li>2. Apply less clamping pressure with tailstock.</li> <li>3. Clean bed surface to remove oil/grease.</li> </ol>
Can't remove tapered tool from tailstock barrel.	<ol style="list-style-type: none"> <li>1. Debris was not removed from taper before inserting into barrel.</li> </ol>	<ol style="list-style-type: none"> <li>1. Always make sure that taper surfaces are clean.</li> </ol>

**NOTE:** ALL ELECTRICAL WORK MUST BE DONE BY A QUALIFIED ELECTRICIAN OR SERVICE ENGINEER.

# SPARE PARTS SECTION

The following section covers the spare parts diagrams and lists that were current at the time this manual was originally printed. Due to continuous improvements of the machine, changes may be made at any time without notification.

## HOW TO ORDER SPARE PARTS

1. Have your machines **model number, serial number & date of manufacture** on hand, these can be found on the specification plate mounted on the machine
2. A scanned copy of your parts list/diagram with required spare part/s identified
3. Go to [www.machineryhouse.com.au/contactus](http://www.machineryhouse.com.au/contactus) and fill out the enquiry form attaching a copy of scanned parts list.

## CONTENTS

Spare Parts WL-18.....	20
Spare Parts List WL-18.....	21
Spare Parts WL-20.....	22
Spare Parts List WL-20.....	23
Wiring diagram.....	24



# OPERATION MANUAL

## Spare Parts WL-18

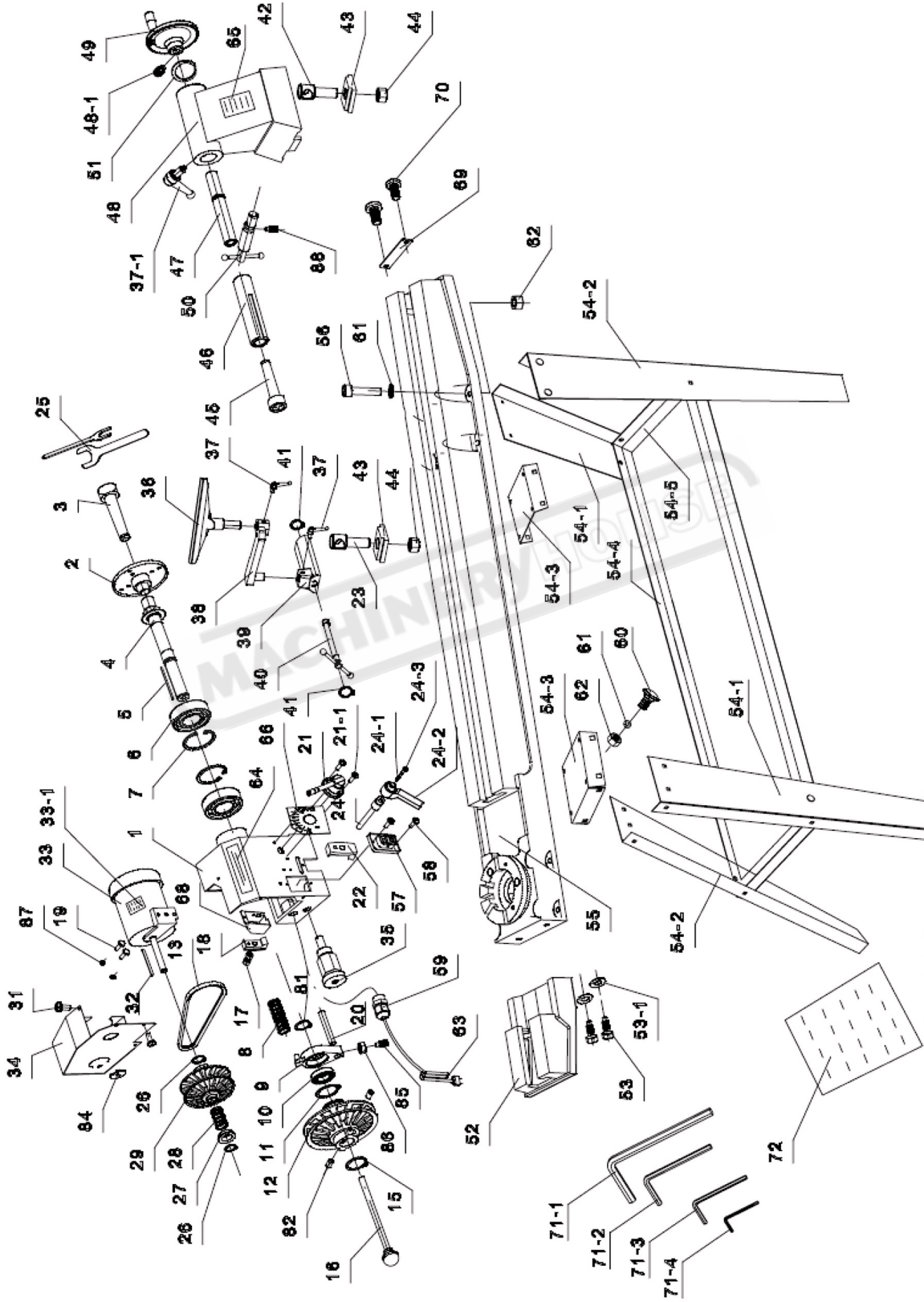



## OPERATION MANUAL

### Spare Parts List WL-18

No.	Description	Qty	No.	Description	Qty
1	HEADSTOCK	1	44	HEX NUT M18	2
2	DISC	1	45	CENTER	1
3	DRIVE CENTER	1	46	TAIL SPINDLE	1
4	SPINDLE	1	47	TAILSTOCK SCREW	1
5	KEY 4 X 4 X 80	1	48	TAILSTOCK	1
6	BALL BEARING 6205Z	2	48-1	SET SCREW M8 X 20	1
7	C-RING S-52	1	49	HANDWHEEL	1
8	SPRING	1	50	LOCK HANDLE-TAILSTOCK	1
9	BRACKET SHIFTING LEVER	1	51	SPECIAL WASHER	1
10	BALL BEARING 6007	1	52	EXTENSION BED	1
11	C-RING S-62	2	53	CAP SCREW M10 X 25	2
12	SPINDLE PULLEY SET R & L	3	53-1	LOCK WASHER 10MM	2
13	V-BELT	3	54-1	STAND LEG, LEFT	2
15	C-RING S-16	1	54-2	STAND LEG, RIGHT	2
16	PIN-INJECTION	1	54-3	STAND UPPER COVER	2
17	LOCK NUT	1	54-4	STAND LONG-CROSS SUPPORT	2
18	CLAMP LEFT	1	54-5	STAND SHORT-CROSS SUPPORT	2
19	HEX BOLT	2	55	BED	1
20	RACK	1	56	CAP SCREW M8 x 35	8
21	GEAR ASSEMBLY	1	57	SWITCH	1
21-1	SCREW M5x12	2	58	SCREW M4x12	2
22	CLAMP RIGHT	1	59	PLASTIC JAM NUT M20 X 1.5	1
23	SPECIAL SCREW	1	60	CARRIAGE BOLT M8 x 12	24
24	SHAFT	1	61	WASHER 8MM	24
24-1	SPRING	1	62	HEX NUT M8	1
24-2	LOCK HANDLE	1	63	POWER CORD	1
24-3	SPECIAL CAP SCREW	1	64	NAME LABEL	1
25	WRENCH	2	65	WARNING LABEL	1
26	C-RING S-16	1	66	MOTOR LABEL	1
27	SLEEVE	1	68	SWITCH BOX	1
28	SPRING	1	69	PLATE	2
29	MOTOR PULLEY SET, L & R	1	70	SCREW M5x10	1
31	SCREW M5x8	4	71-1	WRENCH 8MM	1
32	KEY 4X4X82	1	71-2	WRENCH 6MM	1
33	MOTOR	1	71-3	WRENCH 4MM	1
33-1	MOTOR LABEL	1	71-4	WRENCH 3MM	1
34	MOTOR COVER	1	72	MANUAL	1
35	ANGULAR SETTING ASSEMBLY	1	81	C-RING S-35	1
36	TOOL REST	1	82	SCREW M6x10	4
37	HANDLE FOR TOOL REST	1	84	COVER	1
37-1	HANDLE FOR TAILSTOCK	1	85	SCREW M8x25	1
38	EXTENSION TOOL REST	1	86	NUT M8	2
39	TOOL REST BODY	1	87	WASHER 8MM	2
40	ECCENTRIC ROD	1	88	SCREW M6x12	1
41	C-RING S-19	2	87	WASHER 8MM	2
42	SPECIAL SCREW	1	88	SCREW M6x12	1
43	CLAMP	2			



# OPERATION MANUAL

## Spare Parts WL-20

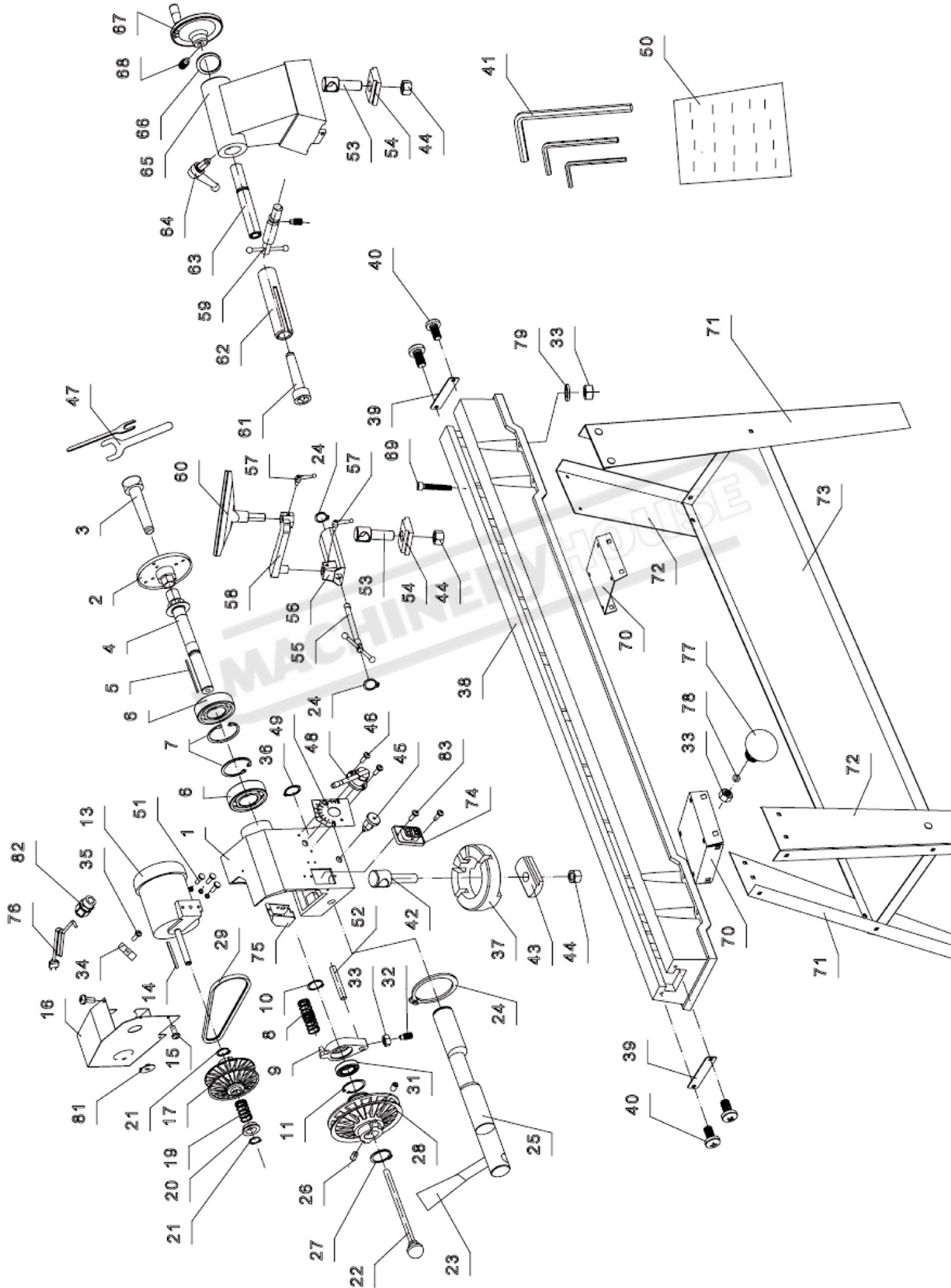

## OPERATION MANUAL

### Spare Parts List WL-20

No.	Description	Qty	No.	Description	Qty
1	HEADSTOCK	1	43	CLAMP-A	1
2	FACE PLATE	1	44	HEX NUT	3
3	HEADSTOCK SPUR	1	45	ANGULAR SETTING ASSEMBLY	1
4	SPINDLE	1	46	SCREW	2
5	KEY	1	47	SPRING WASHER	2
6	BEARING	2	48	GEAR ASSEMBLY	1
7	"C"RING	2	49	SPEED LABEL	1
8	SPRING	1	50	INSTRUCTION MANUAL	1
9	BRACKET-SHIFTING LEVER	1	51	HEX SCREW	3
10	"C"RING	1	52	BACK	1
11	"C"RING	1	53	BOLT-B	2
			54	CLAMP-B	2
13	MOTOR	1	55	ECCENTRIC ROD	1
14	KEY	1	56	TOOL REST BODY	1
15	SCREW	1	57	HANDLE ASSEMBLY	2
16	COVER-MOTOR	1	58	EXTENSION TOOL REST	1
17	PULLEY-MOTOR(RIGHT & LEFT)	1	59	LOCK HANDLE-TAILSTOCK	1
			60	TOOL REST	1
19	SPRING	1	61	TAILSTOCK SPUR	1
20	SLEEVE	1	62	TAIL SPINDLE	1
21	"C"RING	2	63	TAIL STOCK SCREW	1
22	PUSH-OUT ROD	1	64	HANDLE ASSEMBLY	1
23	KNOB	2	65	TAILSTOCK	1
24	"C"RING	3	66	WASHER	1
25	ECCENTRIC ROD	1	67	HANDLE WHEEL	1
26	SCREW	1	68	SCREW	1
27	"C"RING	1	69	SCREW	1
28	PULLEY-SPINDLE(LEFT & RIGHT)	1	70	STAND UPPER COVER	2
29	V-BELT	1	71	STAND LEG, LEFT	2
			72	STAND LEG, RIGHT	2
31	BEARING	1	73	PLATE	1
32	NUT-LOCK	1	74	SWITCH	1
33	NUT	9	75	SWITCH BOX	1
34	CLAMP	2	76	POWER CORD	1
35	NUT M4x40	2	77	CARRIAGE BOLT M8 x 12	20
36	"C"RING	1	78	WASHER 8MM	20
37	TURNING BASE	1	79	WASHER 8MM	8
38	BED	1	80		
39	BAFFLE	2	81	COVER	1
40	SCREW	4	82	PLASTIC JAM NUT M20 X 1.5	1
41	HEX WRENCH	4	83	SCREW	2
42	BOLT-A	1			

**HAFCO WOODMASTER****OPERATION MANUAL****Wiring diagram.**

220-240V/50Hz, 1 Phase

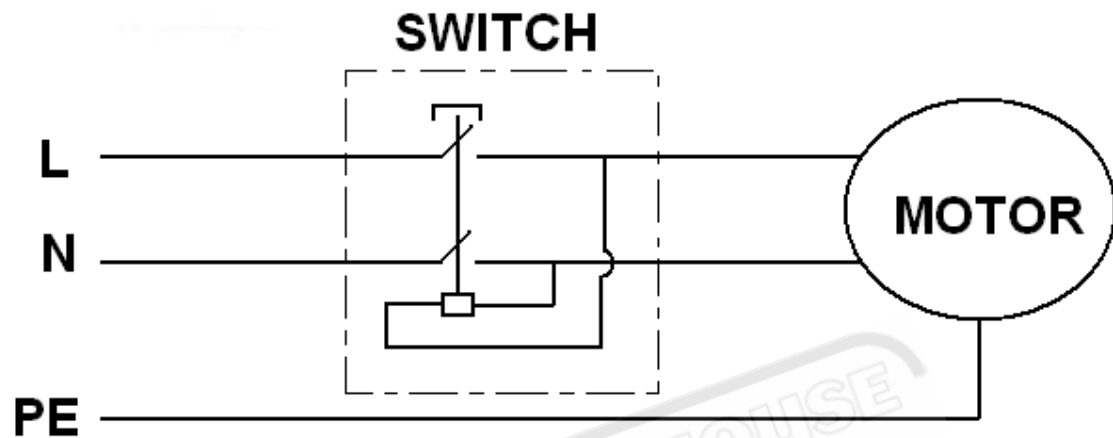



# WARNING

## General Machinery Safety Instructions

---

Machinery House  
requires you to read this entire Manual before using this machine.

- 1. Read the entire Manual before starting machinery.** Machinery may cause serious injury if not correctly used.
- 2. Always use correct hearing protection when operating machinery.** Machinery noise may cause permanent hearing damage.
- 3. Machinery must never be used when tired, or under the influence of drugs or alcohol.** When running machinery you must be alert at all times.
- 4. Wear correct Clothing.** At all times remove all loose clothing, necklaces, rings, jewelry, etc. Long hair must be contained in a hair net. Non-slip protective footwear must be worn.
- 5. Always wear correct respirators around fumes or dust when operating machinery.** Machinery fumes & dust can cause serious respiratory illness. Dust extractors must be used where applicable.
- 6. Always wear correct safety glasses.** When machining you must use the correct eye protection to prevent injuring your eyes.
- 7. Keep work clean and make sure you have good lighting.** Cluttered and dark shadows may cause accidents.
- 8. Personnel must be properly trained or well supervised when operating machinery.** Make sure you have clear and safe understanding of the machine you are operating.
- 9. Keep children and visitors away.** Make sure children and visitors are at a safe distance for you work area.
- 10. Keep your workshop childproof.** Use padlocks, Turn off master power switches and remove start switch keys.
- 11. Never leave machine unattended.** Turn power off and wait till machine has come to a complete stop before leaving the machine unattended.
- 12. Make a safe working environment.** Do not use machine in a damp, wet area, or where flammable or noxious fumes may exist.
- 13. Disconnect main power before service machine.** Make sure power switch is in the off position before re-connecting.
- 14. Use correct amperage extension cords.** Undersized extension cords overheat and lose power. Replace extension cords if they become damaged.
- 15. Keep machine well maintained.** Keep blades sharp and clean for best and safest performance. Follow instructions when lubricating and changing accessories.
- 16. Keep machine well guarded.** Make sure guards on machine are in place and are all working correctly.
- 17. Do not overreach.** Keep proper footing and balance at all times.
- 18. Secure workpiece.** Use clamps or a vice to hold the workpiece where practical. Keeping the workpiece secure will free up your hand to operate the machine and will protect hand from injury.
- 19. Check machine over before operating.** Check machine for damaged parts, loose bolts, Keys and wrenches left on machine and any other conditions that may effect the machines operation. Repair and replace damaged parts.
- 20. Use recommended accessories.** Refer to instruction manual or ask correct service officer when using accessories. The use of improper accessories may cause the risk of injury.
- 21. Do not force machinery.** Work at the speed and capacity at which the machine or accessory was designed.
- 22. Use correct lifting practice.** Always use the correct lifting methods when using machinery. Incorrect lifting methods can cause serious injury.
- 23. Lock mobile bases.** Make sure any mobile bases are locked before using machine.
- 24. Allergic reactions.** Certain metal shavings and cutting fluids may cause an allergic reaction in people and animals, especially when cutting as the fumes can be inhaled. Make sure you know what type of metal and cutting fluid you will be exposed to and how to avoid contamination.
- 25. Call for help.** If at any time you experience difficulties, stop the machine and call you nearest branch service department for help.



# WARNING

## Wood Lathe Safety Instructions

---

Machinery House  
requires you to read this entire Manual before using this machine.

- 1. Maintenance/Adjustments.** Make sure the lathe is turned off and disconnect from the main power supply and make sure all moving parts have come to a complete stop before any inspection, adjustment or maintenance is carried out.
- 2. Lathe Condition.** Lathe must be maintained for a proper working condition. Never operate a lathe that has damaged or worn parts. Scheduled routine maintenance should be performed on a scheduled basis.
- 3. Leaving a Lathe Unattended.** Always shut the lathe off and make sure all moving parts have come to a complete stop before leaving the lathe. An unsupervised running lathe can cause serious injury.
- 4. Avoiding Entanglement.** Remove loose clothing, belts, or jewelry items. Tie up long hair and use the correct hair nets to avoid any entanglement with moving parts.
- 5. Guards safety.** Make sure all guards supplied are in good condition and in place. Make sure the lathe sits on a flat stable surface.
- 6. Eye and Face protection.** Always wear eye protection and a face shield when operating the lathe.
- 7. Respiratory protection.** Always wear a respirator when using the machine. Wood dust may cause allergies or long term respiratory health problems.
- 8. Mounting the workpiece.** Make sure the workpiece is properly embedded on the headstock and tailstock centres. A loose workpiece can be thrown across the room and cause serious injury to you or a by-stander.
- 9. Workpiece clearance.** Rotate the workpiece by hand to check for adequate clearance before turning the lathe on.
- 10. Stopping the lathe.** Do not slow or stop the lathe chuck by using your hand against the workpiece. Allow the lathe to stop on its own.
- 11. Avoiding Entanglement.** Remove loose clothing, belts, or jewelry items. Never wear gloves while machine is in operation. Tie up long hair and use the correct hair nets to avoid any entanglement with moving parts.
- 12. Workpiece condition.** Always inspect the workpiece condition. Check for knots, splits, nails, and any other potentially dangerous conditions. Make sure joints of glued-up pieces have high quality bonds and won't fly apart during operation.
- 13. Adjusting tool rest height.** Always adjust the tool rest to the correct height to provide proper support for the turning tool you will be using. Test the clearance between the tool rest and the workpiece by rotating the workpiece by hand before turning the lathe on.
- 14. Speed selection.** Select the appropriate speed for the type of work, material, and tool bit. Allow the lathe to reach full speed before using.
- 15. Use sharp Chisels.** Keep lathe chisels properly sharpened and held firmly in position when using.
- 16. Faceplate Turning.** When faceplate turning, use lathe chisels on the downward spinning side of the workpiece only.
- 17. Sanding/Polishing.** Remove the tool rest when performing sanding or polishing operations on the rotating spindle.
- 18. Material removal rate.** Removing too much material at once may cause the workpiece to fly out of the lathe.
- 19. Workpiece Vibration.** If the workpiece vibrates, turn off the machine immediately. Check to make sure the workpiece is centered and balanced. Trim excess waste off the corners with a bandsaw or table saw to reduce vibration. Make sure the workpiece is securely attached in setup.
- 20. Power outage.** In the event of a power failure during use of the lathe, turn off all switches to avoid possible sudden start up once power is restored.
- 21. Clean work area.** Keep the area around the lathe clean from oil, tools and chips.
- 22. Call for help.** If at any time you experience difficulties, stop the machine and call your nearest branch service department for help.

## PLANT SAFETY PROGRAM

### **NEW MACHINERY HAZARD IDENTIFICATION, ASSESSMENT & CONTROL**

### **Wood Lathe**

Developed in Co-operation Between A.W.I.S.A and Australia Chamber of Manufactures  
This program is based upon the Safe Work Australia, Code of Practice - Managing Risks of Plant in the Workplace ( WHSA 2011 No10 )

Item No.	Hazard Identification	Hazard Assessment	Risk Control Strategies <small>(Recommended for Purchase / Buyer / User)</small>
A	ENTANGLEMENT	HIGH	Eliminate, avoid loose clothing / Long hair etc.
C	CUTTING, STABBING, PUNCTURING	MEDIUM	Isolate power to machine prior to any checks or maintenance. Do not open or clean inside until the machine has completely stopped.
D	SHEARING STRIKING	MEDIUM	Make sure all guards are secured shut when machine is on.
F		MEDIUM	Ensure workpiece is secured and toolrests are locked tight in correct position. A face mask must be worn at all times. Secure and support heavy material. Remove all loose objects around moving parts. Ensure spindle is in the correct direction before machining.
H	ELECTRICAL	MEDIUM	All electrical enclosures should only be opened with a tool that is not to be kept with the machine.
O	OTHER HAZARDS, NOISE, DUST.	LOW	Wear hearing protection as required. Must be connected to dust extraction
Plant Safety Program to be read in conjunction with manufactures instructions			



[www.machineryhouse.com.au](http://www.machineryhouse.com.au)



[www.machineryhouse.co.nz](http://www.machineryhouse.co.nz)

Authorised and signed by:  
Safety officer:



Manager:



Revised Date: 12th March 2012